

# hydraulic equipment

ADVANCED HEAVE COMPENSATED AND PENDULUM DAMPENED  
OFFSHORE RESCUE BOAT / DAUGHTER CRAFT DAVIT SYSTEM

## HMD G80



The HMD G80 Daughter Craft / Fast Rescue Boat davit system is the most advanced and best suited alternative for handling of 11-12 meter class Fast Rescue Boats, Daughter Crafts, Workboats etc, under extreme weather conditions.

The davit is as standard delivered as a complete, self-contained unit, fully tested and type-approved. Installation to vessel is extremely simple. It is only required to bolt the davit skid frame and towing boom system to pre-installed vessel foundations, interconnect control console/towing boom, fill hydraulic oil and connect electric power supply to vessels electric power system. The davit system is then ready for operation.

The davit is type approved according to latest SOLAS/IMO/MCA/UKOOLS regulations and is  marked.

### Standard equipment:

- One common skid frame houses entire davit system
- Built in electro-hydraulic power unit
- Built in emergency diesel power for dead ship operation
- Automatic operated boat cradle system
- High speed heave compensated winch unit
- Hydro-pneumatic shock dampener
- Two axis hydraulic pendulum dampened docking head
- Towing boom system for boat positioning
- Several towing boom types available (Luffing, slew and telescopic)
- Separate operation console incl. multihose

- Galvanised wire rope
- Stainless steel hydraulic pipes
- Space heater in electric motor
- Centralized lubrication system

### Optional equipment:

- Active heave compensation hook connection system. (See separate technical description) (AHC-HCS system) (Hook connection without relative motion between wire end ring / boat hook)
- Access platforms and ladders
- Top coat paint.
- Electrohydraulic power unit
- El. motor starter cabinet.
- Remote start/stop box with running light.

A reliable  
source for  
quality  
marine/offshore  
equipment



**HYDRAMARINE**

# HMD G80

## Main dimensions

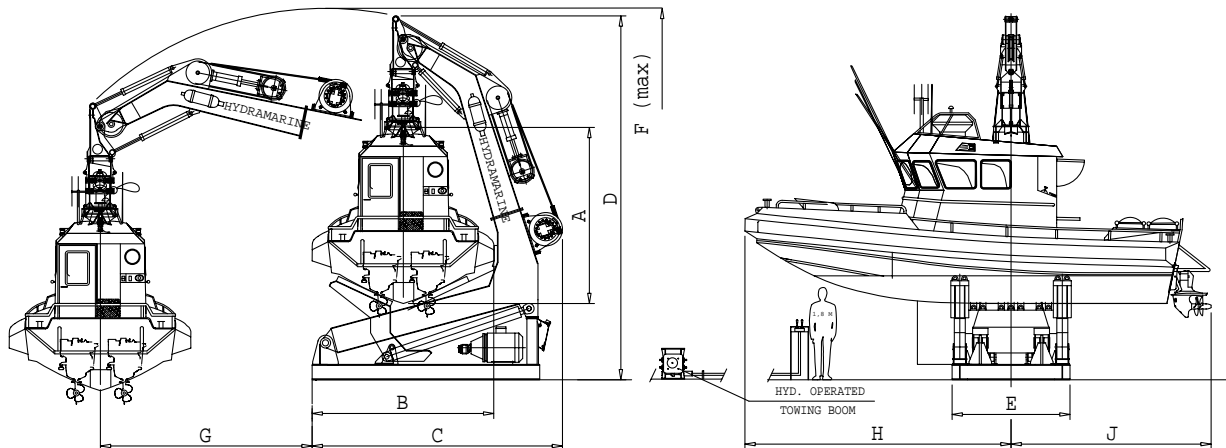

Type	A:	B:	C:	D:	E:	F:	G:	H:	J:
Standard	3400	3500	4890	7100	2300	7250	4000	Boat	Boat

All dimensions approximate and in mm.

## Main technical data

Lifting capacity:	80 kN (8,0 tons)
Davit working outreach:	4,0 meters
Tow boom outreach:	4,0 meters
Hoisting height:	20 meters
Hoisting speed:	0-60 m/min
Heave compensation speed:	0-120 m/min
Max list/trim:	20° + 10°
Power consumption:	145 kW
Total weight:	12000 kg

## Local representative



For detailed information contact us at:  
Andøyveien 23 N-4623 Kristiansand S. Norway  
Phone. +47 38 01 87 00, Fax + 47 38 01 87 01  
E-mail: sales@hydramarine.no, www.hydramarine.com